



OPTEM ARCH



**THE SYSTEM OF PRECAST
BRIDGE-TYPE STRUCTURES**



The optemFRAME original precast bridge system is tailored to the needs of civil engineering constructions. Optem has developed the solution that can be classified as a rigid soil-shell structure.

It meets high demands of the construction market.

We managed to combine effectiveness with short performance time.

As the interaction between the structure and soil was used, we have obtained a product that is highly economical in relation to traditional solutions.

The optemFRAME precast structures allow the construction of:

- overpasses and road bridges,
- railway bridges,
- pedestrian and bicycle underpasses,
- wildlife crossings.

The system consists of:

- optemARCH precast supports that are used interchangeably with monolithic supports being made on the construction site,
- optemARCH precast arch-shaped elements of load-bearing structures.

We have multi-year experience and a large engineering team.

The optemFRAME precast system department is involved in the construction process at every stage of implementation, starting with the design preparation, through the delivery and assembly of the finished elements, to the complete execution of the structure.

The system consists of:

- optemARCH precast walls or monolithic supports
- optemARCH precast arch-shaped elements of load-bearing structures

Elements of the optemARCH system for monolithic supports

Elements of the optemARCH system for precast supports

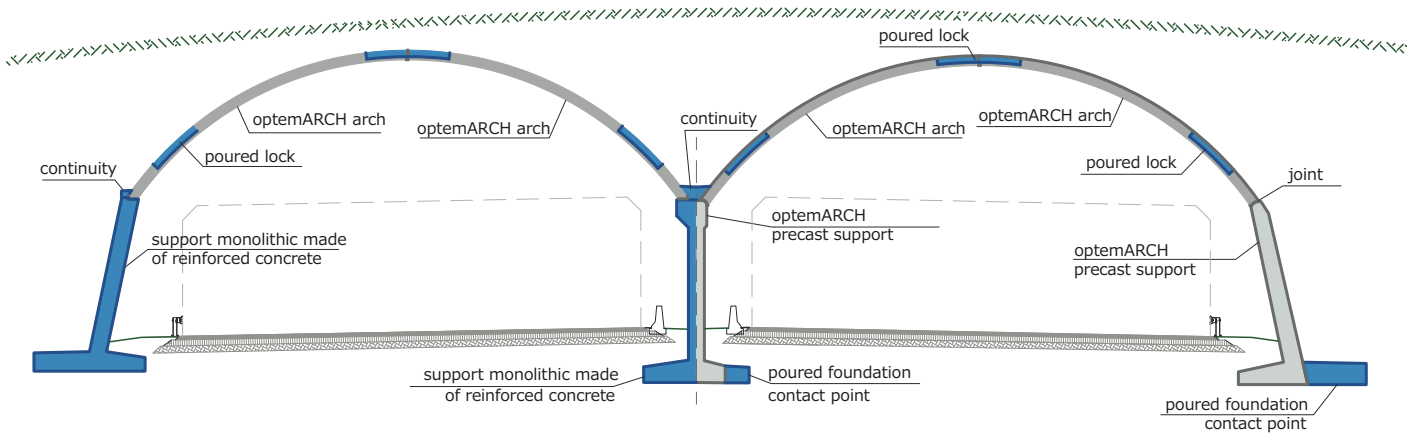

Elements of the optemARCH system for the arch with a shorter span

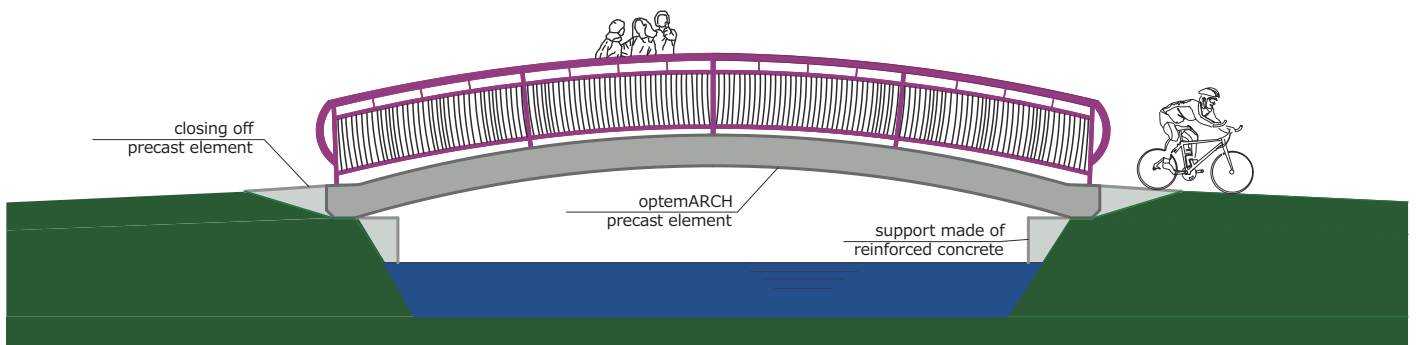
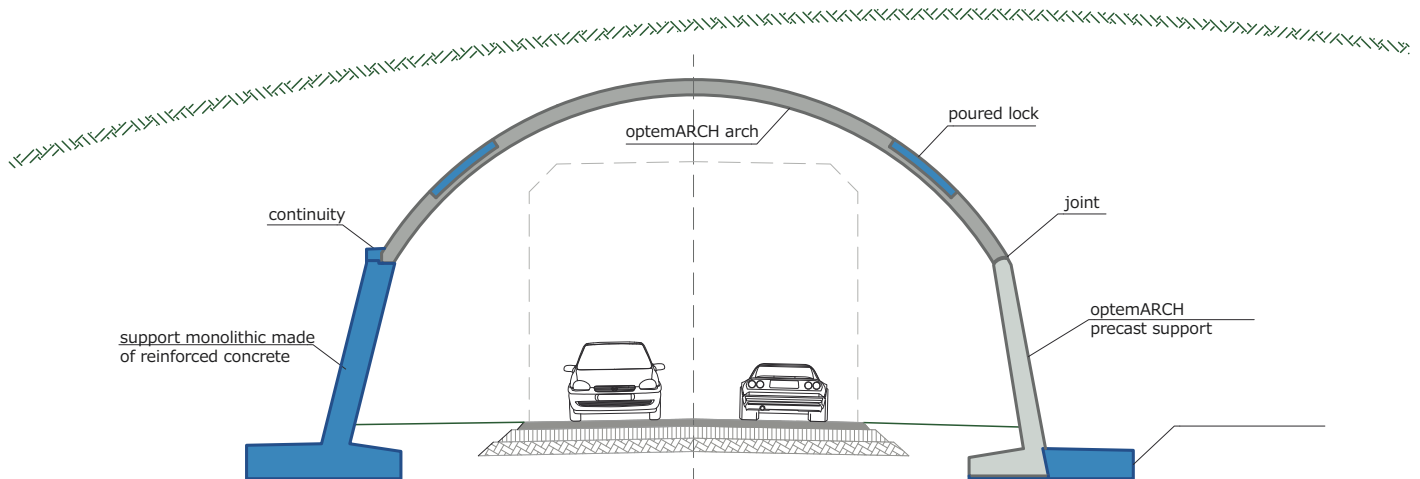

OptemARCH system

Cross-sections of precast elements:

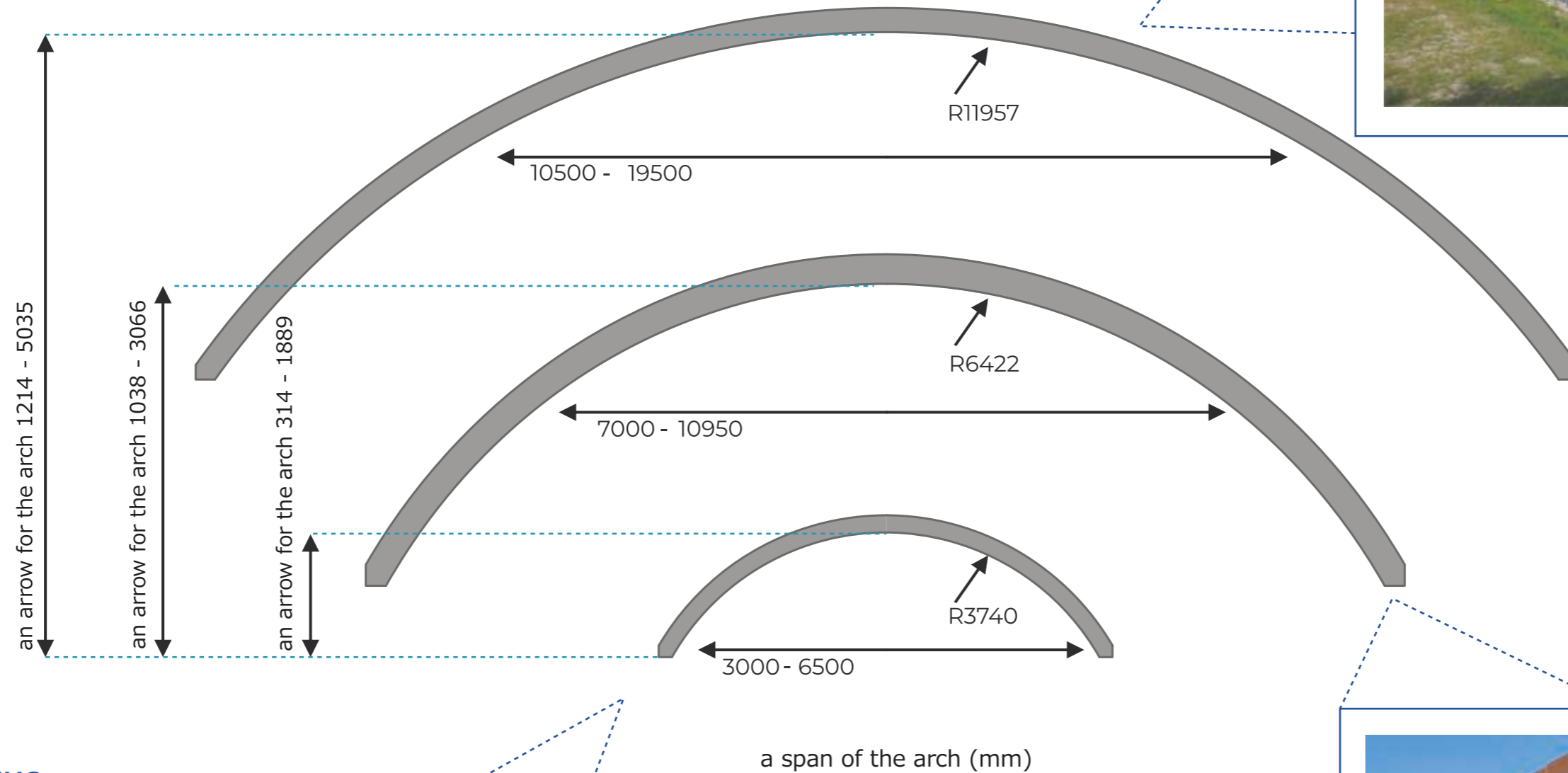

NIDZICA



KOŚCIERZYNA

IWIĘCINO



DURABILITY of optemARCH precast elements

The durability of optemFRAME precast structures is influenced by:

- production of precast elements in certified plants,
- high concrete quality that meets contractual requirements,
- appropriate concrete care,
- tight waterproofing system on the backfill surface side,
- tight connection between precast elements through appropriate joint protection and the formation of a concrete-filled lock between adjacent segments.

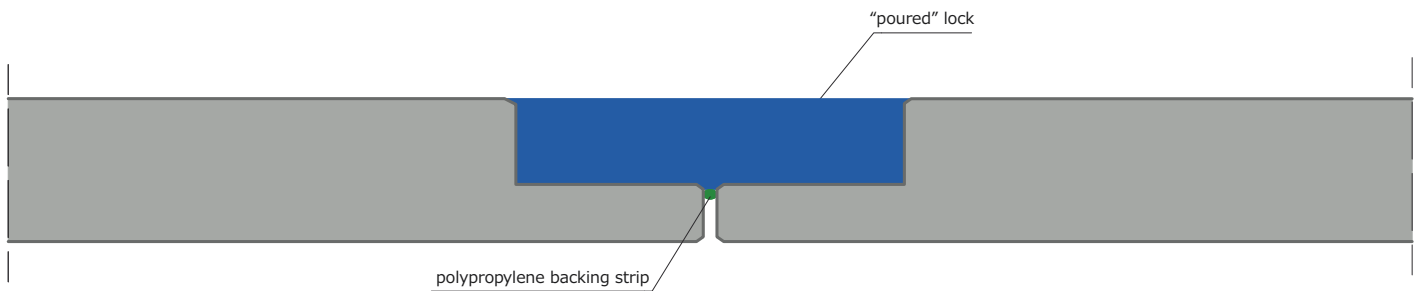

- | |
|---|
| drainage geocomposite |
| natural aggregate with the fraction of 8/16 |
| drainage pipe |
| bentonite mat |
| dispersion asphalt-rubber mass |
| heat-weldable roofing membrane |
| sloping layer CI2/15 |
| continuous node C30/37 |

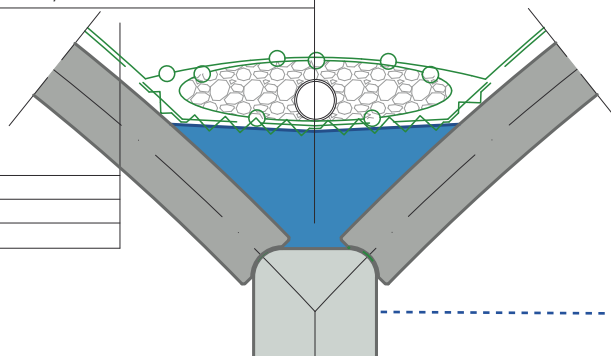

- | |
|--------------------------------|
| drainage geocomposite |
| dispersion asphalt-rubber mass |
| "optemARCH" precast element |



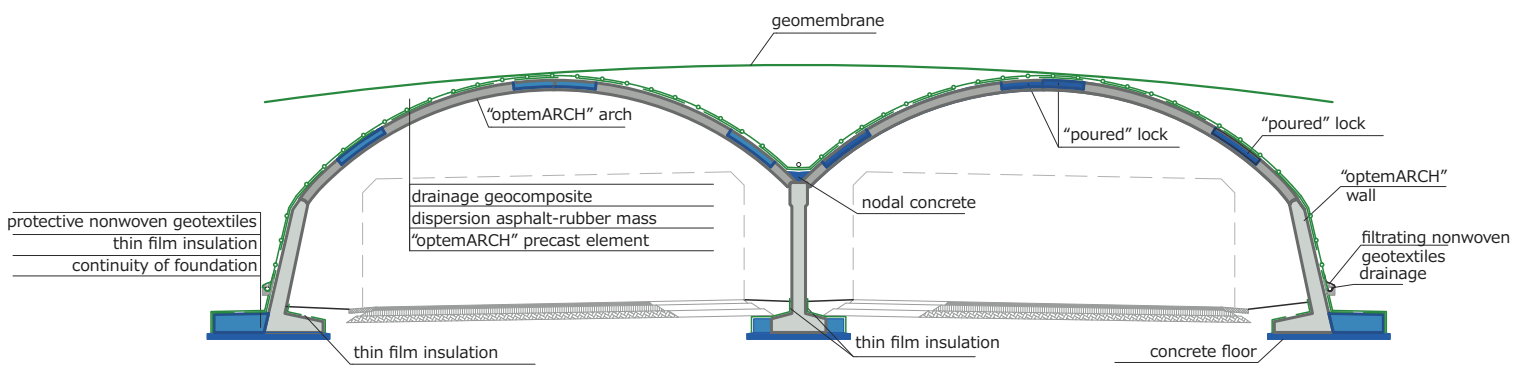

The advantages of constructing bridge-type structures with the use of optemARCH precast elements:

- fast pace of structure completion,
- possibility to optimize the thickness of elements thanks to the use of the arch shape and shell structure,
- low material consumption thanks to uniquely developed system in which individual precast elements interact with each other,
- higher durability of precast structures due to high specifications of the applied concrete
- tightness of the structure thanks to the usage of a tested insulation system,
- the economy of structure maintenance due to the lack of any devices such as bearings, expansion joints, threaded connections.

INNOVATIVENESS of the optemARCH system

The Optem company together with Road and Bridge Department in Rzeszów University of Technology were conducting a research project: **“Innovative precast arch-shaped elements of increased durability for transport infrastructure engineering”**, which aim was to develop a new **optemARCH** precast arch-shaped element.

As a part of the project, the research was conducted on the innovative precast element made of lightweight concrete with a composite reinforcement. As a comparison, the research on the traditional precast element made of normal concrete with steel reinforcement was conducted as well. As a result, a significantly improved construction product that was characterized by lower weight and increased corrosion resistance was obtained.



THE INTERACTION of the optemARCH system with the optemBLOK system

The optemFRAME technology works closely together with the optemBLOK system.

Benefits of the connection:

- The OPTEM company has extensive experience in designing both systems. By using the systems from the same company the structure is treated in a comprehensive and complete way. Problems with coordination are avoided,
- Fast erection of the optemBLOK technology retaining walls compared to the traditional reinforced concrete walls,
- Aesthetics of walls made with precast concrete blocks.

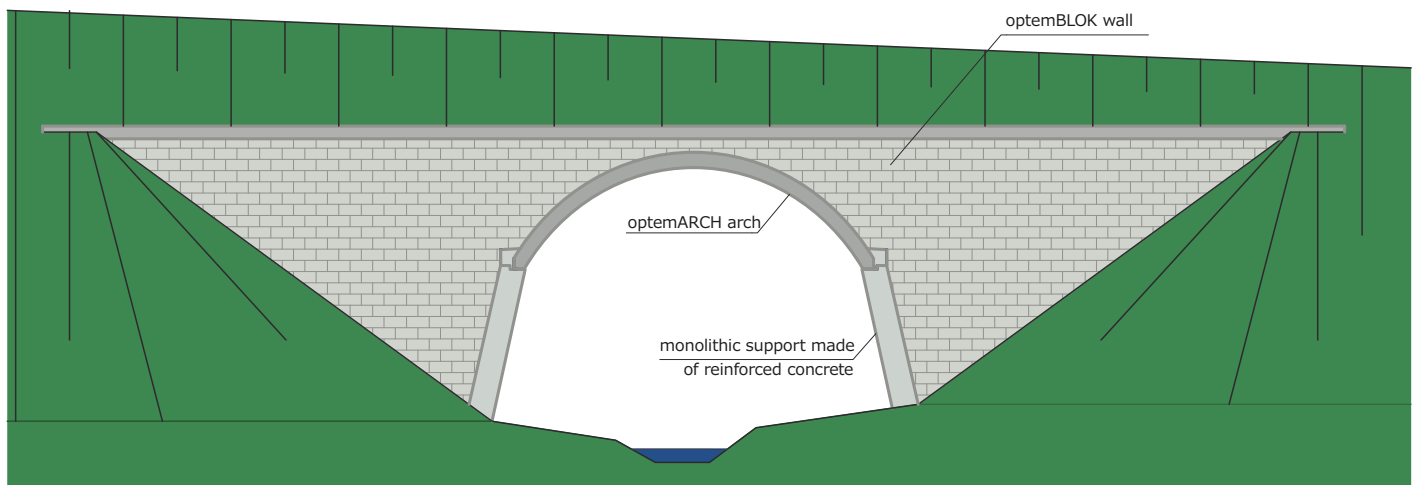

EXAMPLE OF THE TWO SYSTEMS COMBINATION





S7

Nidzica-Napierki stretch of road

Description of the investment:

As a part of the investment, a wildlife crossing over the S-7 Expressway and National Road no. 7 was designed. The structure is 98.06 m in length, and 80 m in width. Prefabricated arch-shaped segments were placed on precast system walls.

The total duration of the structure installation that consisted of 285 precast elements was 38 working days.

Location: Nidzica

Used products:
optemARCH



The construction of Koscierzyna bypass within the Stargard-Gdynia section of the National Road no. 20

Description of the investment:

The PZ-2 wildlife crossing was constructed when performing the Koscierzyna bypass. The structure is 22.57 m in length, while the width of the wildlife crossing is 7 m. The load-bearing structure consists of 9 precast arch-shaped, reinforced-concrete elements based on precast walls of the optemARCH system. The installation of all 27 precast elements lasted 4 days.

Location: Koscierzyna

Used products:

optemARCH, optemFROG



Railway no. 20: Warszawa Główna Towarowa – Warszawa Praga

Description of the investment:

The crossing below a track system was constructed during repairs on the bypass railway line in Warsaw. Due to the possibility to completely shut off the existing stretch of the railway line, 5 precast arch-shaped, reinforced-concrete elements on monolithic supports were designed.

Location: Warszawa

Used products:
optemARCH





S-19 Lublin-Rzeszów, Krasnik-Janów Lubelski stretch of road

Description of the investment:

As a part of the investment, seven bridge-type structures were designed and constructed. They ensure the collision-free establishment of the S19 Expressway over obstacles. Every structure is a single-span frame with a precast arch-shaped bolt that is connected with monolithic supports. All structures required the usage of 118 precast elements with a total length of 275 m.

Location: Janów Lubelski

Used products:
optemARCH



A1 Tuszyn, C stretch of road Kamiensk junction (without a junction) Radomsko junction (with a junction)

Description of the investment:

As a part of the investment, the engineering structure was designed and constructed for the purpose of collision-free migration of large animals over the A1 Motorway. The wildlife crossing was designed as a four-span structure of precast arches based on reinforced-concrete walls. On the entrance and exit of the structure, reinforced-concrete retaining walls with the optemBLOK small-size concrete masonry units siding were designed. The structure was constructed in a so-called partial-closure technology due to the necessity of maintaining traffic on the existing road.

Location: Janów Lubelski

Used products:
optemARCH



OPTEM Group consists of:

DESIGN OFFICE

- **bridge** department
- **building** department
- **geotechnics** department
- **road** department

THE DEPARTMENT OF INVESTMENT PERFORMANCE

- the construction of precast bridge-type structures: **optemARCH**, **optemFRAME** and **optemPLATE**
- the construction of the **optem BLOK** retaining walls
- the construction of engineering structures
- the construction of building structures

OPTEM

THE DEPARTMENT OF TECHNOLOGY

- **optemARCH** – Precast concrete arch bridge system
- **optemFRAME** – Precast concrete frame bridge system
- **optem PLATE** –Buried corrugated steel structure system
- **optem BLOK** –Reinforced earth retaining wall system with small-sized precast concrete blocks
- **optemFROC** - Precast concrete amphibian/reptile protective fencing system



ONE COMPANY – MULTIPLE SOLUTIONS

ONE COMPANY – MULTIPLE SOLUTIONS

Optem

ul. Grota-Roweckiego 12
80-108 Gdańsk
Tel. (+48) 58 346-40-40
biuro@optem.pl
www.optem.pl